



Gloria Espresso Machine SAE 2 Group Package (including Mazzer grinder and Knockout Drawer)

Installation Specification

Electrical Power

Electrical Requirement Gloria SAE 2 Group:	20amp Single Phase
Electrical Requirement Mazzer grinder:	13amp standard socket

Electrical power is needed within 1 metre of the machine.

Water Supply

A 15mm cold water supply with stopcock is required within 1 metres of the machine.

CTU Water Filter

Space of 300mm (Depth) x 300mm (Width) x 600mm (Height) is required under the counter to house the Carbon Water Filter.

Safety

Working counter should be at a height of 900mm and able to withstand a weight of 100Kg

Water & Waste

Water and waste services require a service hole to be drilled no smaller than 80mm diameter. See drawing for hole location. Mains drainage or a suitable receptacle is required, beneath the counter, for coffee waste.

Space Requirement

In addition to the dimensions given below, space is recommended to accommodate 6 cups and saucers, either in front or to the left of the machine.

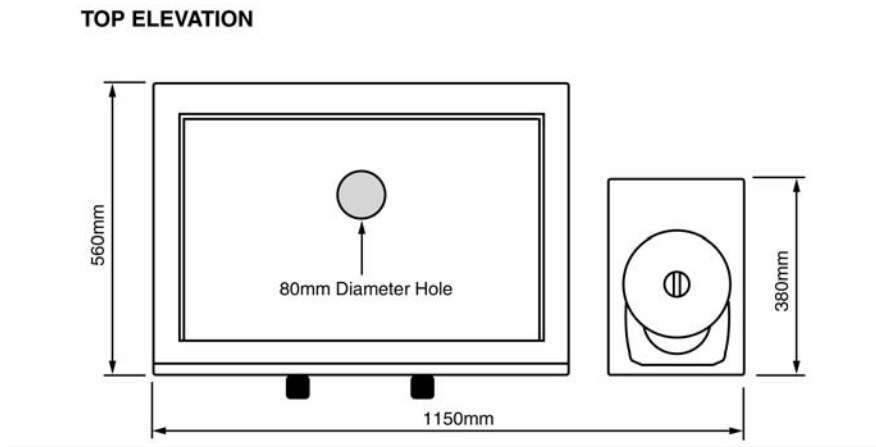
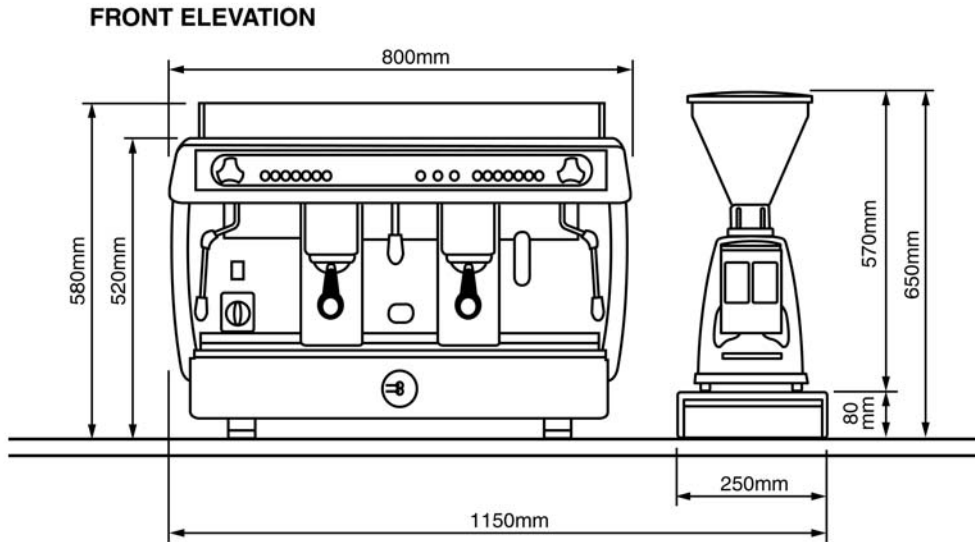

Should any of the above services not be available at the agreed time of installation, a charge of £120.00 will be made for failed installation.

Installation Address _____

Site Contact Name _____ Tel. No. _____

Date of installation _____

Signed and agreed by _____